

IRONWOOD

8kW Woodburning Stove



User Instruction Manual



Issued January 2024, Document No. IWO8M01

IRONWOOD

8kW Woodburning Stove

Thank you for purchasing the Ironwood 8kW woodburning stove. Follow these simple instructions and guidelines to ensure you get the best and safest operation from your Ironwood stove.

General

To ensure the safe installation of this appliance it must be installed by a Hetas registered engineer or approved by your local building control officer.

- Only burn approved fuels
- Regular maintenance and chimney sweeping is required (see care & maintenance)
- Do not make any unauthorised modifications or changes to the appliance.
- Do not place combustible materials such as fuel close to or in close proximity to the appliance
- Furniture should be at least 1 metre in distance from the appliance

Please refer the installer to the current issues of British Standards BS EN 15287-1:2007 design, installation, and commissioning of chimneys.

Technical information

Nominal Heat Output	8 kW
Efficiency	80.2%
Fuel	Wood Only
Model	IWO8KW
Weight	125Kg
Width	580mm
Depth	390mm
Height	645mm
Spigot internal dimension	155mm
Distance from rear to centre of spigot	135mm
Distance to combustibles	Side 470mm Rear 560mm
Intermittent operation only	

Dimensions

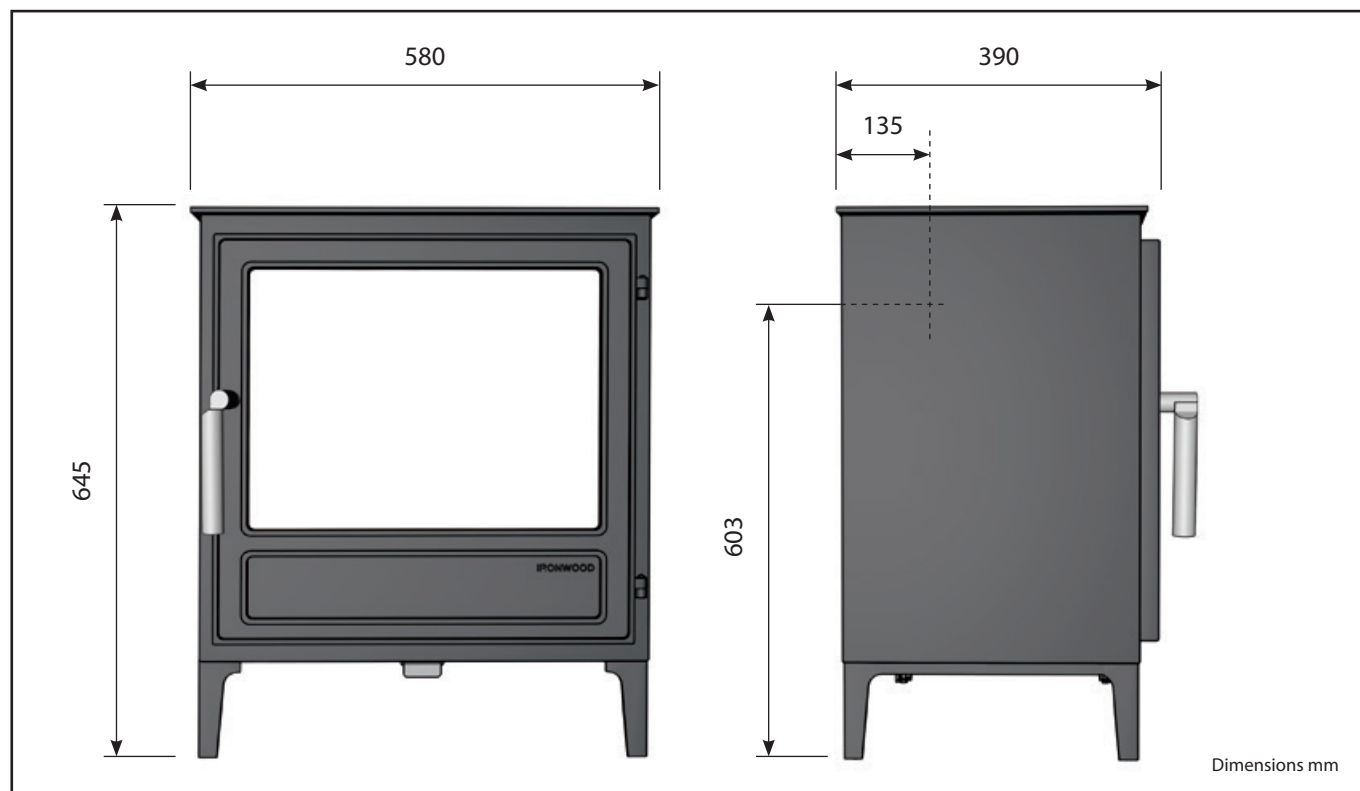

Recommended fuels

Ironwood stoves are designed for burning wood only. Choosing the correct log length is important and this depends on the type and size of the stove. For the Ironwood 8kW we recommend a 14" log which will ensure you get a long clean burn by having the size to comfortably fit the firebox and grate. Most importantly is ensuring the wood you choose is dry with a moisture content of no more than 20%. If the fuel is damp with a high moisture content this will result in poor combustion and also result in layers of soot and tar within the firebox chamber and chimney. This could potentially cause a chimney fire if allowed to build up over time. The glass will also mist up and the crystal clear view of the fire will be disrupted.



Burn only seasoned or kiln dried firewood with a moisture content of less than 20%. We recommend using 'Ready to Burn' fuel from an accredited Woodsure fuel supplier.

Do not

- **Do not burn unsuitable fuels such as treated waste wood (eg old furniture, pallets or fence panels) or household rubbish. Treated waste wood and household rubbish can emit harmful fumes and toxic pollutants into your home when burnt.**
- **Do not use liquid fuels as a fuel or an incinerator.**

Lighting the first fire

The first few fires should be kept at a low temperature with a few sticks of kindling in order for any cement and seals to harden. On the third fire the temperature can be increased and logs introduced. At this stage the temperature will increase allowing the stove paint to cure and harden.

It is normal that the curing paint will smell and even create a misty haze in the room, a window or door to outdoors should be opened. The smell should stop after the first few firings. Take care not to touch the stove paintwork as during the curing process the paint is soft and can mark easily.

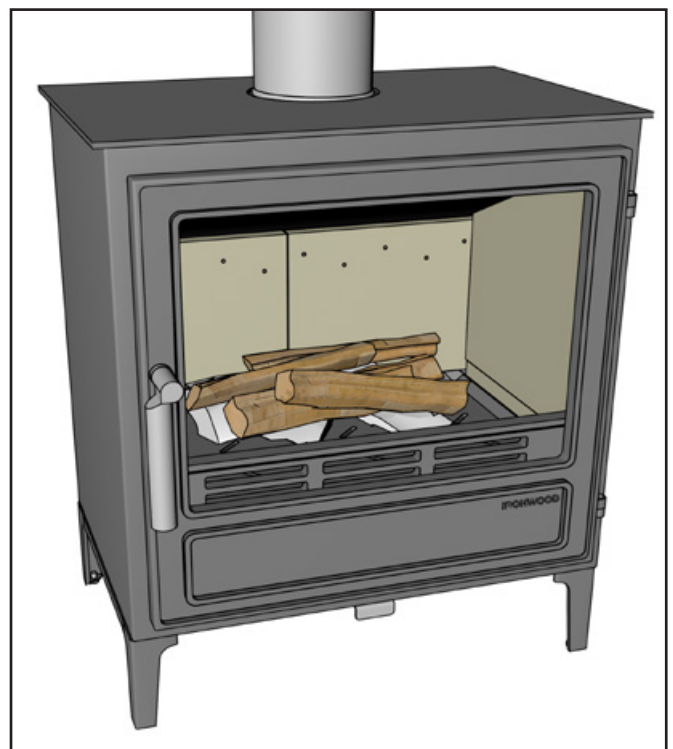

Lighting and controlling the fire

Warning: This appliance will be hot to touch during operation. Ensure a pair of stove gloves are worn at all times when operating and refuelling the appliance.

STEP 1

Lighting- fully open, 2nd 'click'

Pull the air wash lever open towards you which will fully open all necessary vents to start the fire. Place firelighters/ newspaper and dry kindling wood on the grate. Light the paper or firelighters and leave the door ajar to allow the fire to establish. Add a few small diameter logs and after the fire is established larger logs can be introduced, usually after 10-15 minutes. The stove door should be closed fully at this point. Move to step 2.

Do not run the fire with the door ajar except for initial lighting and refuelling as this can cause over firing and damage the appliance.

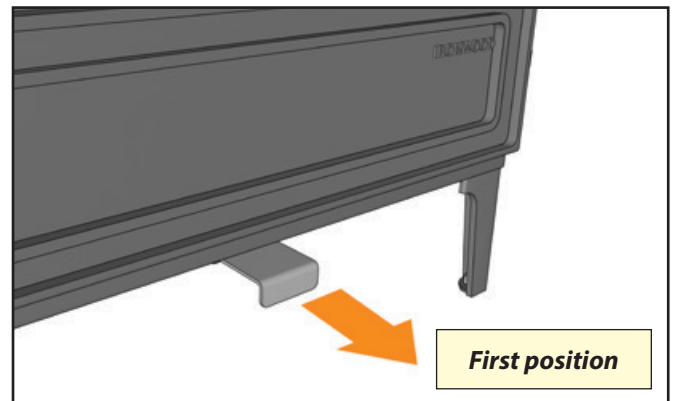

STEP 2

Moving towards optimum temperature

When an optimum temperature of between 150 and 250 Celsius on the outer body of the stove is reached push the slider again further towards the stove to its second location. This will reduce the secondary air and slow the rate off enough to allow the stove to operate at its optimum temperature, where you can see the flames and slow efficient burning of the logs.

Burning seasoned or kiln dried wood with a moisture content of under 20% is essential for a smooth transition to optimum stove temperature.

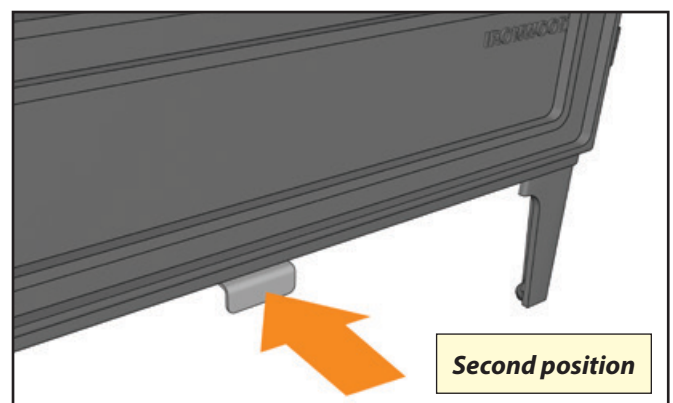

STEP 3

Refuelling

Open the air vent fully for a few minutes before refuelling. Slowly open the stove door and place one or 2 logs diagonally onto the fire grate. The door should be left ajar for a period of around 3 minutes with the air vent slider open in order to maintain flames on a new re-fuel charge.

Once the fire is established close the door and push the slider to the second location. The appliance is designed to be used with the door closed.

As a guideline refuel intervals are every 40-50 minutes. Ensure that the firebox is not loaded above the combustion inlets on the rear firebrick.



De-ashing

Wood burns best on a bed of ash approximately 25mm (1" deep). Remove any excess ash from the firebox by using an ash rake or a small shovel which will allow the ash to fall into the ashpan below the grate. The ashpan can be removed by opening the stove door and pulling out the ash tray beneath the grate.

Place the ash in an ash caddy or suitable metal container. Do not place hot ash in a container made from plastic or combustible material.

Ash can remain hot for a long period of time after use, ensure sufficient time has lapsed before removing. We recommend de-ashing once a week.

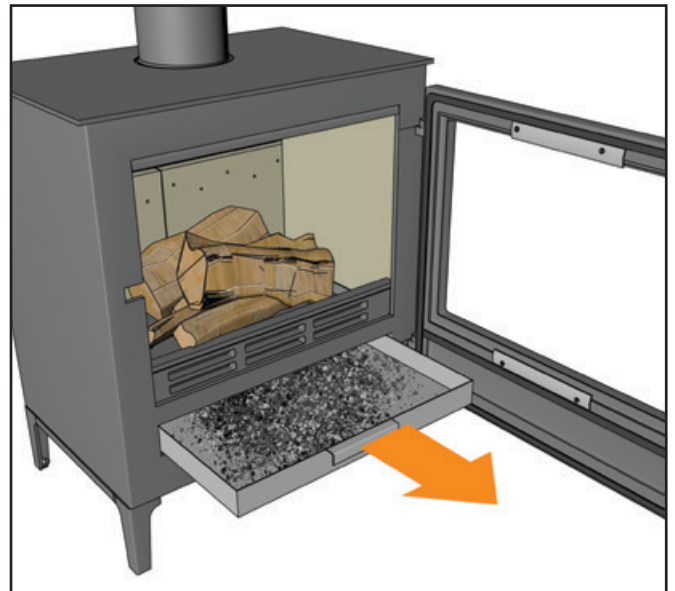

Refuelling on to a low fire bed

If there is insufficient burning material in the firebed to light a new fuel charge, excessive smoke emission can occur. Refuelling must be carried out onto a sufficient quantity of glowing embers and ash that will allow the new fuel charge to ignite in a reasonable period. If there are too few embers in the fire bed, add suitable kindling to prevent excessive smoke.

Fuel overloading

The maximum amount of fuel specified in this manual should not be exceeded, overloading can cause excess smoke.

Operation with door left open

Operation with the door open can cause excess smoke. The appliance must not be operated with the appliance door left open except as directed in the instructions.

Dampers left open

Operation with the air controls or dampers open can cause excess smoke. The appliance must not be operated with air controls or dampers door left open except as directed in the instructions.

Installation instructions

Installation of this appliance must be by a registered Hetas engineer or approved by your local building control officer. All local regulations including those referring to National and European Standards need to be complied with when installing this appliance.

Connection to top outlet

As standard the stove will be supplied with a top flue connection. Fire cement or heat resistant rope should be inserted into the spigot or around the male end of the pipe to allow a tight fit. A mechanical fixing such as a self-tapping screw or rivet is required to secure the pipe into position. While this connection is made we advise to lift the stove top in order to give the space required

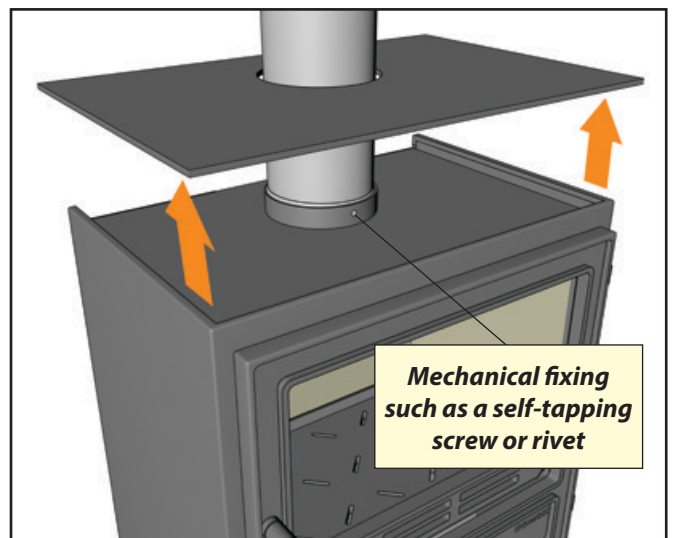
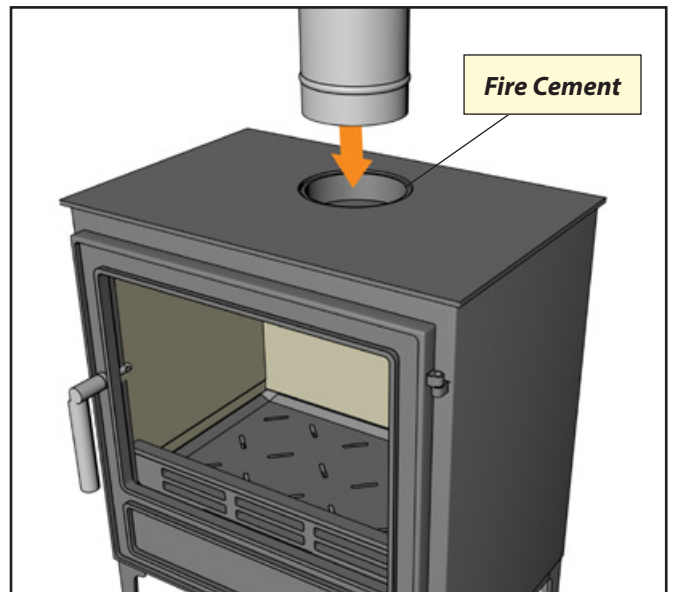

Connection to rear outlet

Unscrew the top spigot and rear plate using a 10mm spanner and 4mm allen key. Reposition the spigot onto the rear of the stove and ensure the gasket is fitted inbetween the body of the stove and the spigot. Insert a tee piece into the spigot with fire cement or heat resistant rope and secure with mechanical fixing such as a self-tapping screw or rivet.

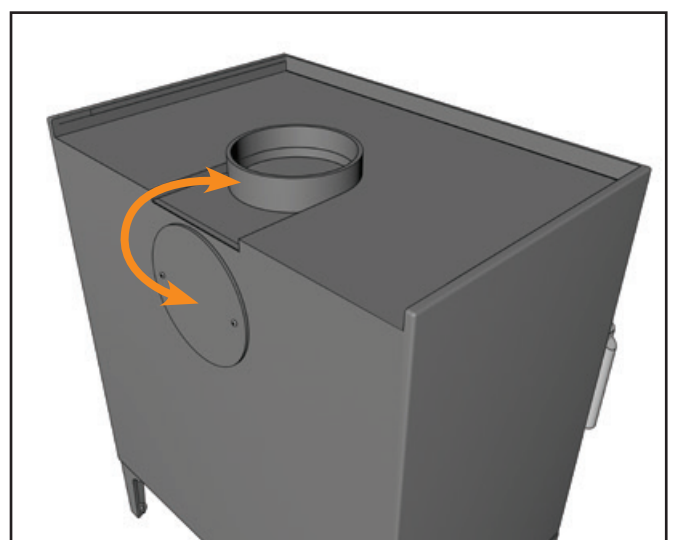

Defra exemption

The Ironwood 8kW Stove has been recommended as suitable for use in smoke control areas when burning wood logs. This is conditional upon following the wood burning instructions precisely. Suitable Authorised fuels can also be used in the appliances in Smoke Control Areas. See Authorised fuel list:

<https://smokecontrol.defra.gov.uk/fuels.php>

Further information on the requirements of the Clean Air Act can be found here:

<http://smokecontrol.defra.gov.uk>

Your local authority is responsible for implementing the Clean Air Act 1993 including designation and supervision of smoke control areas and you can contact them for details of Clean Air Act requirements.

This stove can be used in Smoke Control Areas by inserting the 5mm bolt (supplied) to the underside air slider of the stove (see diagram below).

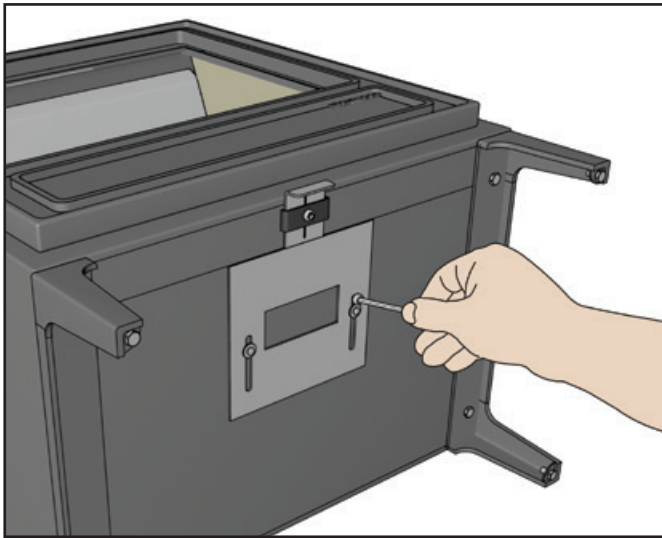

The Clean Air Act 1993 and Smoke Control Areas

Under the Clean Air Act local authorities may declare the whole or part of the district of the authority to be a smoke control area. It is an offence to emit smoke from a chimney of a building, from a furnace or from any fixed boiler if located in a designated smoke control area. It is also an offence to acquire an “unauthorised fuel” for use within a smoke control area unless it is used in an “exempt” appliance (“exempted” from the controls which generally apply in the smoke control area).

In England appliances are exempted by publication on a list by the Secretary of State in accordance with changes made to sections 20 and 21 of the Clean Air Act 1993 by section 15 of the Deregulation Act 2015. Similarly in Scotland appliances are exempted by publication on a list by Scottish Ministers under section 50 of the Regulatory Reform (Scotland) Act 2014.

In Wales and Northern Ireland these are authorised by regulations made by Welsh Ministers and by the Department of the Environment respectively.

Further information on the requirements of the Clean Air Act can be found here at:

<https://www.gov.uk/smoke-control-area-rules>

Your local authority is responsible for implementing the Clean Air Act 1993 including designation and supervision of smoke control areas and you can contact them for details of Clean Air Act requirements.

The Ironwood 5kW Wide Woodburning Stove has been recommended as suitable for use in smoke control areas when burning wood logs. The Ironwood 5kW Wide Woodburning Stove must be fitted with a permanent stop to prevent closure of the air control slide plate beyond 22.4mm open.

Carbon monoxide alarm

The regulations currently state that “appropriate provision shall be made to detect and give warning of the release of CO”. This is covered in Approved Document J of the Building Regulations that the statutory requirements for installations of solid fuel appliances. In particular regulation J3 states the following:

Warning of Release of Carbon Monoxide

J3. |Where a fixed combustion appliance is provided, appropriate provision shall be made to detect and give warning of the release of carbon monoxide.

A suitable alarm will have been tested to confirm it meets the necessary requirements of BS EN 50291:2010, and activate within the required time when the relevant volume of CO is detected. The alarm packaging itself will contain the relevant information, including appropriate Kitemark reference (if tested by BSI) and also confirmation of the test method standard, warning of the expected lifetime of the sensor and where incorporated stating the product includes an end of life indication.

The general provisions within ADJ and BS8303 ask that the CO alarm be positioned in a location which provides means for the immediate detection of CO upon spillage from a solid fuel appliance. Guidance in ADJ and in BS8303 is that CO alarms should be positioned as follows;

- On the ceiling at least 300mm from any wall or, if it is located on a wall as high up as possible (above any doors or windows) but not within 150mm of the ceiling; and
- Between 1m and 3m horizontally from the appliance.

Health & Safety Precautions

Special care must be taken when installing the stove such that the requirements of the Health and Safety at Work Act are met.

Handling

Adequate facilities must be available for loading, unloading and site handling.

Fire Cement

Some types of fire cement are caustic and should not be allowed to come into contact with the skin. In case of contact wash immediately with plenty of water.

Asbestos

This stove contains no asbestos. If there is a possibility of disturbing any asbestos in the course of installation then please seek specialist guidance and use appropriate protective equipment.

Metal Parts

When installing or servicing this stove care should be taken to avoid the possibility of personal injury.

Installation guidance

The chimney must be swept and examined for soundness and suitability before the appliance is installed. Remedial action should be taken if required, seeking expert advice if necessary. Where the chimney is believed to have previously served an open fire installation it is possible that the higher flue gas temperature from a closed appliance may loosen deposits that were previously firmly adhered, with the consequent risk of flue blockage. It is therefore recommended that the chimney be swept a second time within a month of regular use after installation.

Ensure that the flue pipe diameter is not less than the diameter of the outlet of the appliance. If a cooker hood is employed in the same room ensure that adequate air is available for the appliance as well as the hood.

Advise the user what to do should smoke or fumes be emitted from the stove. The customer should be warned to use a fireguard to BS 8423:2002 (Replaces BS 6539) in the presence of children, aged and/or infirm persons.

Commissioning Instructions

Ensure all parts are fitted in accordance with the instructions.

On completion of the installation allow a suitable period of time for any fire cement and mortar to dry out, before lighting the stove. Once the stove is under fire check all seals for soundness and check that the flue is functioning correctly and that all products of combustion are vented safely to atmosphere via the chimney terminal.

On completion of the installation and commissioning ensure that the operating instructions for the stove are left with the customer. Ensure to advise the customer on the correct use of the appliance and warn them to use only the recommended fuel for the stove.

Advise the user what to do should smoke or fumes be emitted from the stove. The customer should be warned to use a fireguard to BS 8423:2002 (Replaces BS 6539) in the presence of children, aged and/or infirm persons.

Warning Note

Properly installed, operated and maintained this stove will not emit fumes into the dwelling. Occasional fumes from de-ashing and re-fuelling may occur. However, persistent fume emission is potentially dangerous and must not be tolerated. If fume emission does persist, then the following immediate action should be taken:-

- (a) Open doors and windows to ventilate the room and then leave the premises.
- (b) Let the fire go out.
- (c) Check for flue or chimney blockage and clean if required
- (d) Do not attempt to relight the fire until the cause of the fume emission has been identified and corrected. If necessary seek expert advice.

The most common cause of fume emission is flueway or chimney blockage. For your own safety these must be kept clean at all times.

Aerosol Spray

To refresh painted finishes a touch up aerosol spray is available. Do not use aerosol sprays near the appliance when under fire.

Over firing

Your stove fuel should burn with a bright energetic flame but you should avoid a furnace-like roaring fire, this is known as 'over firing'. Over firing a stove is caused by excessive oxygen reaching the fire which can cause a heavy heat development liable to damage both the stove and the surrounding walls. This can be due to:

- Incorrectly adjusted air control settings
- Using incorrect fuel type. You must ONLY burn seasoned dry wood. Do not treated wood / builders waste, restricted solid fuels such as house coal, petro coke and anything with a high petroleum or bitumen content.
- Assuming that neither of those situations apply, check that all door and glass seals are in good order and have no gaps.

Make sure you're familiar with all the controls on the stove and proper operation as detailed in this instruction manual.

What to do in the event of a chimney fire

In the event of a chimney fire:

1. **Close off the air controls immediately.**
2. **Leave the room, close the door and alert other people in the house.**
3. **Evacuate the property and call the fire brigade.**
4. **Do not re-enter the property until it is confirmed safe.**

Do not use until a registered engineer has inspected the chimney and appliance to confirm the system is safe and free from obstruction. Only use genuine Ironwood parts in the event that stove parts require replacing.

For ventilation requirements please refer to Approved Document J.

Many older properties are sufficiently ventilated by natural leakage of air to provide suitable air supply for an appliance of 5kW output or less.

Modern building construction has meant that properties have become more air tight. If the air tightness of a modern property is less than 5m³ per hour per m² a purpose air vent is required for a 5kW rated stove. The air leakage of a modern house is tested on completion of construction and a certificate should detail the information required.

An inadequate air supply can result in a poor combustion. This appliance requires a constant supply of air to maintain good combustion.

Extractor fans or cooker hoods must not be placed in the same room as this can cause fumes to emit into the room.

Care & Maintenance

Annual service

Before the start of the heating season an inspection must be made and the appliance cleaned as detailed below. It is important to ensure when any service or cleaning is undertaken the appliance has had time to fully cool.

Visual checks should be made to ensure the following are in good condition:

Stove glass and door rope

Side and rear firebricks

Baffle plate

Grate and log retainer

Door Locking Mechanism

Chimney sweeping

When burning seasoned or kiln dried wood you should sweep your chimney at least once a year. Ideally the chimney should be swept before, during and after the heating season. Sweeping the connecting flue pipe and chimney keeps the chimney clear from blockages to ensure

that the appliance operates efficiently and safely. Access to cleaning the chimney is made by removing the firebrick and baffle plate (see page 9).

Always check that the sweep is qualified and leaves a sweeping certificate.

Chimney Sweeps:

NACS

The national Association of Chimney Sweeps
nacs.org.uk

GOMCS

The Guild Of Master Chimney Sweeps
www.guildofmasterchimneysweeps.co.uk

APICS

The Association of Professional Independent Chimney Sweeps
apics.org.uk

SWEEPSAFE

www.sweepsafe.com

HETAS

hetas.co.uk/find-chimney-sweep/

Air Supply

A permanent air entry opening or openings with a total free area of at least 550mm² per kW of appliance rated output above 5kW should be fitted into the room - **Document J (Table 2.1: Air supply to solid fuel appliances)**

Hearth

The Ironwood 8kW must stand on a floor with adequate load bearing capacity and on top of a fireproof non-combustible hearth of a minimum of 12mm in thickness. The stove must not be positioned closer than the minimum distance from any combustible material (see declaration of performance page 12). Building regulations state the hearth must extend in front of the stove by at least 225mm and 150mm either side of the appliance.

Flue Type

The stove is designed to run on a 6" (155mm) Diameter Flue) and a flue pipe diameter less than 6" diameter should not be used. This stove has the option of rear or top flue which can be changed by removing the blanking plate at the rear of the stove. Ensure the high temperature gasket is in place to create an airtight seal between the stove body and the blanking plate.

Fireguards

In the presence of children, old aged and/or infirm people a fireguard should be placed in front of and to the sides of the appliance. The fireguard should be manufactured in accordance with BS 8423:2002, Fireguards for use with solid fuel appliances.

Removing the baffle plate and firebricks

When sweeping the appliance the baffle plate must be removed. This can be achieved by removing first the left hand firebrick by tilting the top of the firebrick in towards the centre of the appliance and lifting out through the front opening. The baffle plate can then be lowered into the stove and through the front. To remove the rear firebricks the grate has to be removed.

Removing the Grate

Remove the left hand firebrick by tilting the top of the firebrick in towards the centre of the stove and lifting out through the front of the appliance. A spacer brick to the left of the grate can then be removed by prying the brick upwards through the aperture underneath the grate. The grate can be positioned to the left allowing the right hand firebrick to be removed as illustrated. To remove the cast iron grate first remove the horizontal retaining bar by removing the 2 x fixing bolts, then the grate is to be moved vertically and then taken out of the front opening of the fire.

Only use replacement parts supplied or recommended by Ironwood Stoves.

When removing the firebricks check for any damage and clean the fire brick with a soft brush. Care should be taken as the firebricks are fragile. If the brick has a hairline crack or any damage they must be replaced.

Any packaging or consumable items such as firebricks or glass should be recycled or disposed of responsibly at their end of life.

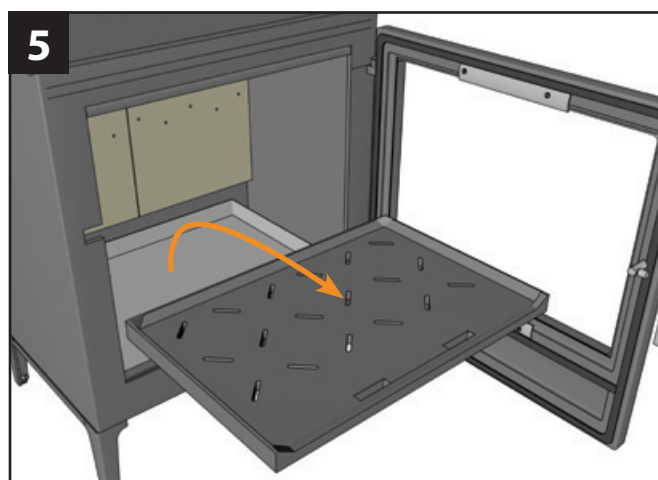
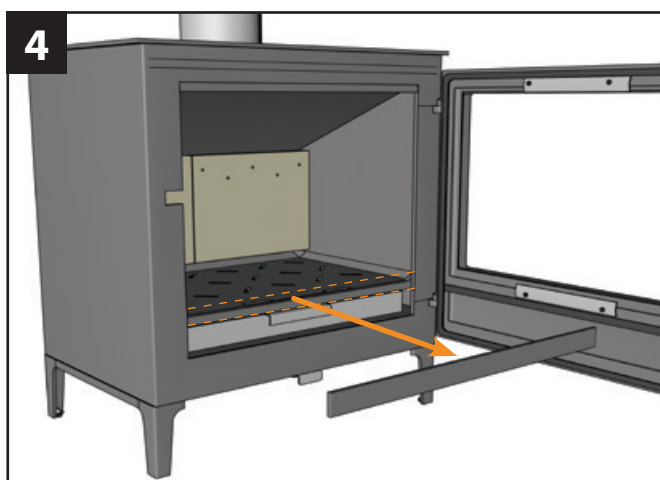
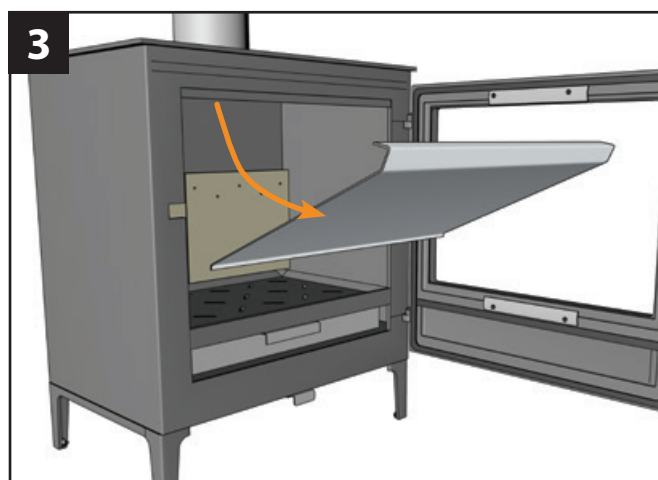
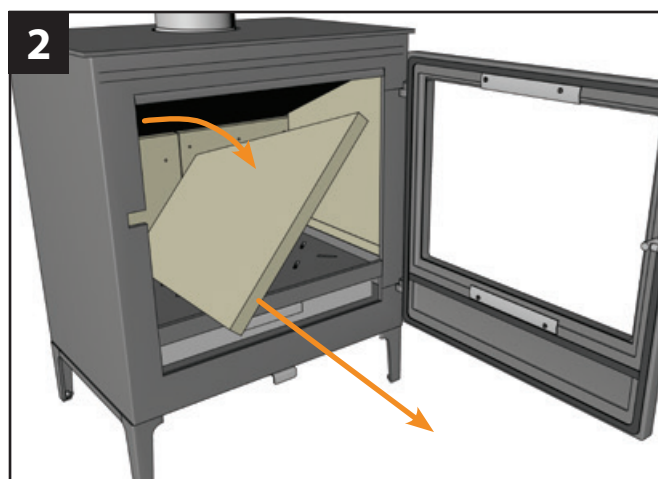
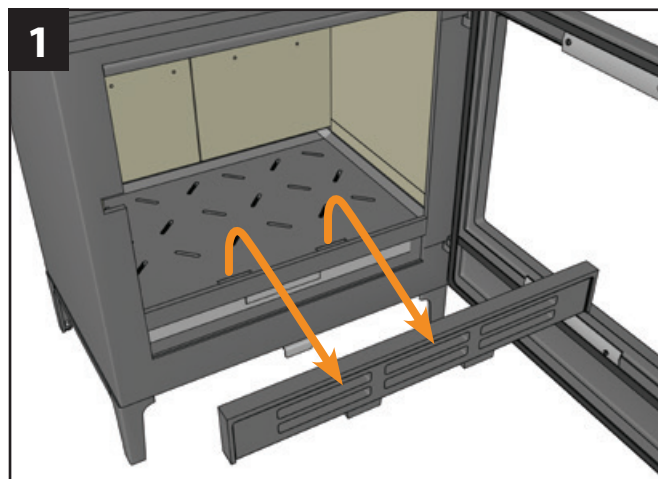

Replacing the glass and door rope

To maintain a safe operation of the stove door any damaged glass should be replaced immediately. Remove the door by lifting from the hinges and lay down on a soft flat surface. Remove the glass fixing strips and fit new glass into position. Be careful not to overtighten the screws as this can break the glass. To fit a new door seal remove the rope and any residue adhesive. Insert rope adhesive into the channel and replacement rope. Wait approximately 12 hours for the rope adhesive to set before using the stove.

Glass dimensions: 407 x 312 x 4mm

Rope diameter: 10mm (soft rope)

Seasonal use

Over the summer months, when the stove is not in use remove all ash and soot from within the ash pan and above the baffle plate. Set the air control to the halfway position as this will reduce any build-up of moisture in the stove and reduce any corrosion. In the event that there is rust on any of the components this can be removed using wire wool and 2 light coats of stove paint.

Periodically remove the handle mechanism using a 3mm allen key. Apply a small amount of copper grease where the mechanism goes through the door casting.

After a prolonged period of not using the appliance a check for blockages will need to be made before re-lighting.

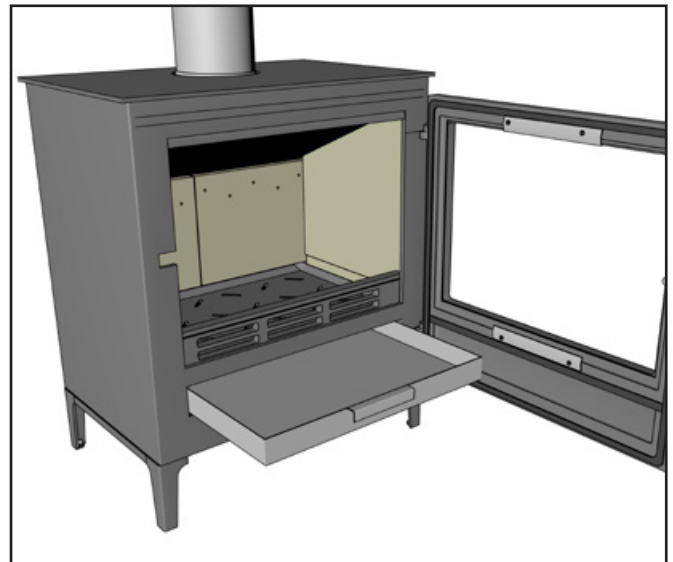
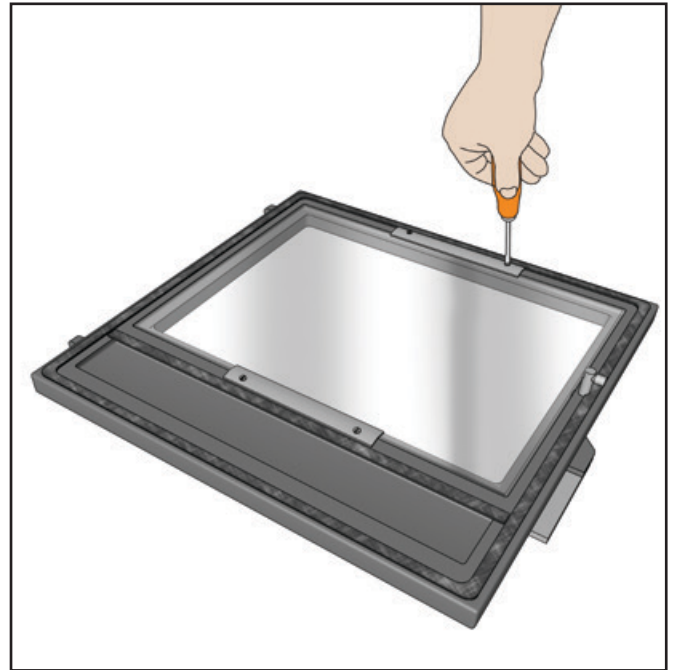

Cleaning and painting of the stove

A can of IRONWOOD High Temperature Stove Paint is supplied with each new stove and can be purchased from your nearest Ironwood retailer. This paint is a quality, fast drying paint for use on stainless steel pipe where a tough coating is required that withstands temperatures of up to 650 C. Ensure the work area is well-ventilated and you are not spraying near naked flames and that the stove is not in operation. Make sure all surfaces are free from dirt, dust and rust using a soft brush or lint free cloth, masking tape and newspaper can be used to cover the stove glass and fittings. Direct nozzle towards object and hold can between 300 - 375mm (12-15") from surface to be sprayed. Press spray firmly and use steady even strokes. Several thin coats give a better finish than one heavy coat. Do not apply more paint than is necessary. During the painting process, whilst drying and for the first 3 times you use your appliance open windows, doors and if necessary use fans to provide a fresh airflow as the paint may give off fumes and smokes. Use kindling only on the first 2 fires burning for 15-20 minutes with the second burn being started whilst the appliance is still warm. A full fire should be burnt for 45-60 minutes again starting whilst the stove is still warm then allowed to cool naturally.

Operating the stove in various weather conditions.

The way the wind affects the chimney can have a big impact on how your stove reacts under various wind loads; you may need to adjust the airflow to achieve good combustion.

It is very important that the operating temperature is reached as quickly as possible on days when the draught in the chimney is poor due to unfavourable wind and weather conditions such as fog and mist. You will need to get a few flames going as quickly as possible. Chop the wood extra thin and use the top down burning method with the larger logs placed at the bottom with smaller logs and kindling added to the top. On top of the kindling add 2-3 firelighters. This method will allow the stove to reach its operating temperature quickly.

Trouble Shooting

Symptom	Possible Cause	Solution
Difficulty in reaching an efficient burn	Wet wood	Ensure fuel is under 20% moisture content (use a moisture meter)
Poor control of the fire and over heating	High flue draft	Consult your installer who may advise use of an anti downdraft cowl
Excessive fuel use	Fuel too dry	Ensure fuel is not too dry. Do not use construction or building timber. Ensure door seals are not broken.
Fire burns too quickly	Excess air into firebox	Reduce the setting on the air controller. Ensure the door seals are not broken.
Low heat output	Low flue draft	Consult a Hetas registered installer to check your flue system
Smoke spillage into the room	Blocked flue	Open all doors and windows and allow the fire to burn out. Consult a stove installer or chimney sweep.
Strong smell into the room	Paint curing	For the first few burns the appliance paint will be curing, open all doors and windows to ensure good ventilation
Wind noise from chimney	High draft	Consult your installer who may advise use of an anti downdraft cowl.

Note that a poor selection of fuel will result in an inefficient burn in the appliance which can further cause:

- Low heat output
- Blackening of stove glass
- Dirty firebricks
- A rapid build up of tar and creosote in the chimney

To ensure a clean and efficient burn use only seasoned or kiln dried firewood with a moisture content of less than 20%. We recommend using 'Ready to Burn' fuel from an accredited Woodsure fuel supplier.

DECLARATION OF PERFORMANCE

MANUFACTURER: TOPSTAK LTD

ADDRESS: UNIT 42, VALE BUSINESS PARK, LLANDOW, CF71 7PF

APPLIANCE: IRONWOOD 8KW WOODBURNING STOVE

PRODUCT TYPE: ROOMHEATER FIRED BY WOOD LOGS WITHOUT SUPPLY OF HOT WATER

VERIFICATION TYPE: SYSTEM 3

PERFORMANCE AGAINST HARMONISED STANDARDS: BS EN 13240:2001 + A2:2004

DOCUMENT NUMBER: IWOGP 23.01.2024

PERFORMANCE TEST RESULTS:

Wood Results, 0.80 hour refuels, All efficiencies in table are Net values

Parameter		A23/153-1	A23/153-2	A23/153-3	Mean
Test Duration	h	0.75	0.83	0.80	0.79
Total Efficiency	%	80.8	80.4	79.4	80.2
Nominal heat output	kW	8.1	7.5	7.6	7.7
Mean CO ₂ emission	%	12.7	12.3	12.5	12.5
Mean CO emission	%	0.11	0.13	0.15	0.13
Mean CO emission (at 13 % O ₂)	%	0.07	0.08	0.09	0.08
Mean CO emission (at 13 % O ₂)	mg/Nm ³	845	1028	1174	1016
Mean flue gas temperature	°C	304	303	319	309
Flue gas mass flow	g/s	5.4	5.2	5.3	5.3
Mean CnHm emission (at 13 % O _v)	mg/Nm ³	47	37	75	53
Mean NOx emission (at 13 % O ₂)	mg/Nm ³	78	82	75	78
Particulates (at 13 % O ₂)	mg/Nm ³	22	17	24	21

TESTING LABORATORY: BY KIWA LTD. KIWA HOUSE, MALVERN VIEW BUSINESS PARK, STELLA WAY, CHELTENHAM, GL52 7DQ UKAS TESTING LABORATORY NO. 0558 REPORT NO. 61810

TEMPERATURE SAFETY TESTING – Minimum Distance to Combustible Material

REAR WALL 560mm

SIDE WALL 470mm

ENERGY EFFICIENCY: A

FIRE HAZARD DUE TO FUEL FALLING OUT: PASS

MAXIMUM HEARTH TEMPERATURES

DIRECTLY UNDER STOVE 50.2°C

225MM IN FRONT OF STOVE 124.5°C

300MM IN FRONT OF STOVE 104.2°C

400MM IN FRONT OF STOVE 116.3°C

THIS DECLARATION OF PERFORMANCE IS ISSUED UNDER THE RESPONSIBILITY OF THE MANUFACTURER.

SIGNED FOR ON BEHALF OF THE MANUFACTURER BY ADAM PEDERSEN 23ND JANUARY 2024



Product Fiche



Commission Delegated Regulation (EU) 2015/1186 Energy Labelling of Local Space Heaters

Manufacturer Name:	Topstak Ltd.
Model Name:	Ironwood 8kW
Energy Efficiency Class:	A
Energy Efficiency Index	106
Nominal Heat Output to Room:	8.0
Net Efficiency:	80.2
Seasonal Efficiency:	70.2

Comments/Installation/Handover Instruction:

IRONWOOD

Tel: 01446 771567

www.ironwoodstoves.co.uk